

UB-QX-PM-ARB

ANTI ROTATION BRACKET

U-Bracket Hardware

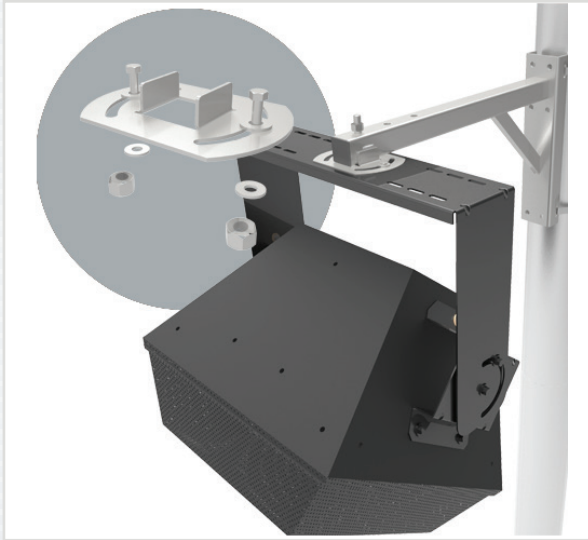

UB-QX-PM-ARB mounted to UB-QX300

Adaptive's UB-QX-PM-ARB pairs the UB-QX300 and UB-QX500 U-Bracket to PoleStar™ pole mounts allowing installers the ability to suspend EAW QX-300 and QX-500 speakers from poles. Once paired with pole mounts the bracket offers up to 90 degrees of rotation. Once desired angle is achieved, bracket can be tightened permanently and will prevent rotation.

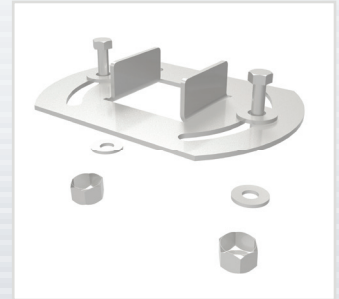

STANDARD FEATURES:

- ▶ Pairs UB-QX300 & 500 to PoleStar™ pole mounting hardware.
- ▶ Allows up to 90° of pan rotation.
- ▶ Once tightened, prevents rotation.

OPTIONAL APPLICATIONS:

- ▶ UB-QX300 U-Bracket
- ▶ UB-QX500 U-Bracket
- ▶ PM-24-6DOWN-G
- ▶ PM-SA-24
- ▶ PM-24-6UP-G

SPECIFICATIONS:

Material: Steel Alloy
Finish: Galvanized
Color: Silver
WLL: N/A

CONTENTS:

1pc: Anti rotation bracket
1pkg: Hardware Kit

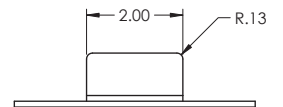
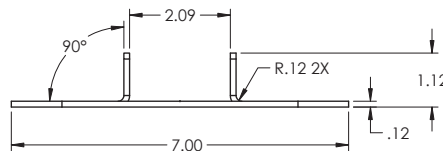
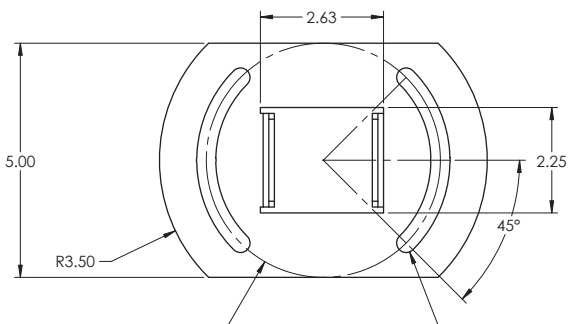

Rated for outdoor use.

Adaptive Technologies Group
1635 E. Burnett Street | Signal Hill, CA 90755 USA
Ph: 562.424.1100 | Fax: 562.424.3520
www.adapttechgroup.com



ALWAYS INSTALL SAFETY CABLES

WARNING: Mounting and/or suspension of audio and video equipment requires experienced professionals. Improperly installed loudspeakers can result in property damage, personal injury and/or liability to the installing contractor.