

# FP-DX15-3x1

(400 lb. WLL)

## CLUSTER PACK PLANAR ARRAY KIT

FASPAC™



Clustering and flying Fulcrum DX15 series loudspeakers is easy, safe and very predictable. This planar array suspension kit joins three DX15 cabinets together to be flown as one, tight-packed for near field placement or splayed out for further distances from the audience.

Four front joiner plates and two rear joiner plates come in the kit. Load rated eyebolts provide the actual suspension by anchoring into the cabinet's threaded attach points. High strength bolts are provided to secure the joiner plates.

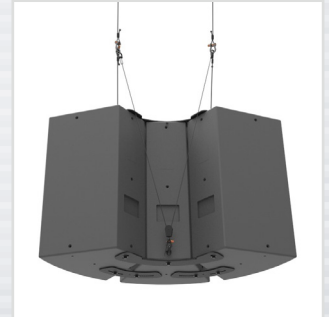

### SPECIFICATIONS:

**Material:** Structural Steel  
**Finish:** Powder coat  
**Colors:** Black  
**Design Factor:** 5:1 ratio  
**Working Load Limit:** 400 lb./ 182Kg.  
**Shipping Weight :** 30 lb. / 13.64 Kg.

### PACKAGE CONTENTS:

**4pcs** Front Joiner Plate  
**2pcs** Rear Joiner Plates  
**2pcs** Eyebolt, M10X35mm  
**2pcs** Eyebolt, M10X50mm  
**1pc** Hardware Kit



Rated for indoor use.

### DIMENSIONS:

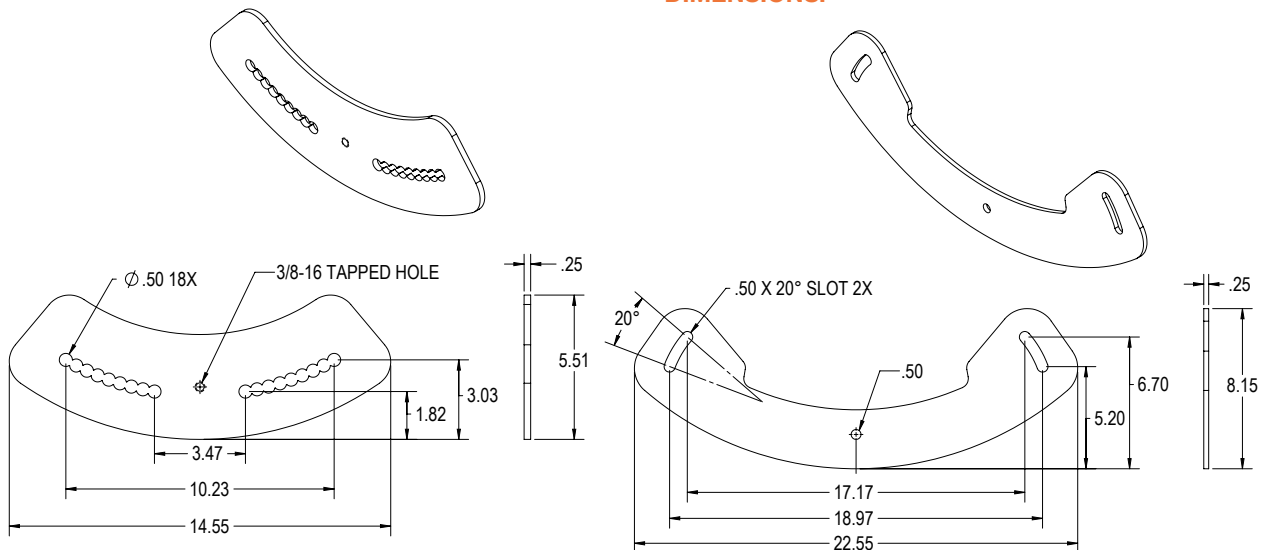

**Adaptive Technologies Group**  
1635 E. Burnett Street | Signal Hill, CA 90755 USA  
Ph: 562.424.1100 | Fax: 562.424.3520  
www.adaptivetechgroup.com



### ALWAYS INSTALL SAFETY CABLES

**WARNING:** Mounting and/or suspension of equipment requires experienced professionals. Improperly installed equipment can result in property damage, personal injury and/or liability to the installing contractor.