

UB-MT-500NPT ASSEMBLY INSTALLATION GUIDE:

1. ASSEMBLE SPEAKER TO U-BRACKET (REFER TO U-BRACKET INSTALLATION GUIDE).
2. ATTACH UB-MT-500NPT TO THE TUBE EXTENSION FROM ABOVE. MAKE SURE TO LOOSEN THE SET SCREW SO THAT THE TUBE EXTENSION CAN EASILY BE SCREWED INTO THE COUPLING OF THE TUBE ADAPTER MOUNT. DO NOT TIGHTEN THE SET SCREW YET UNTIL FINAL SPEAKER DIRECTION IS SET (FIGURE 1).
3. ATTACH THE U-BRACKET WITH SPEAKER (OPTIONAL TO ATTACH SPEAKER TO U-BRACKET) TO THE UB-MT-500NPT USING THE PROVIDED SCREWS, NUTS AND FLAT WASHERS. TIGHTEN PERMANENTLY. MAKE SURE TO USE THE APPROPRIATE BOLTS TO U-BRACKET AND THE TUBE ADAPTER MOUNT (FIGURE 1). TIGHTEN BOLTS PERMANENTLY.

NOTE:
FOR THE U-BRACKETS THAT HAVE THE SMALLER HOLES ON THE BASE, USE THE PROVIDED 5/16 BOLTS, FLAT WASHERS AND NUTS.

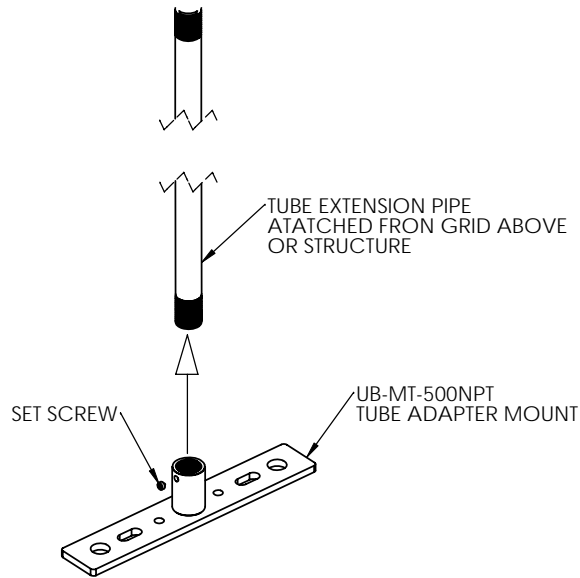

FIGURE 1

4. TIGHTEN SET SCREW ON THE COUPLING TO SECURE THE PIPE FROM ROTATING (FIGURE 1 AND 2)

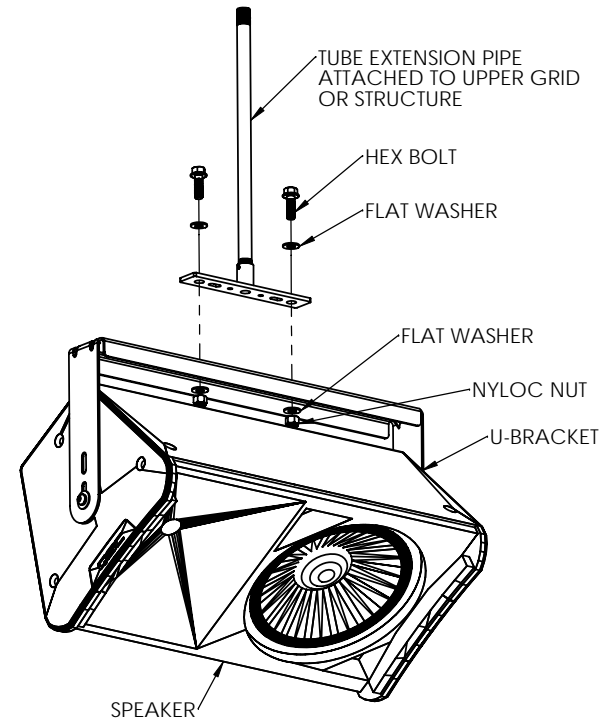

FIGURE 2

BILL OF MATERIAL REVISIONS				
ZONE	REV.	DESCRIPTION	DATE	APPROVED

PROPRIETARY AND CONFIDENTIAL THIS DRAWING IS THE PROPERTY OF ADAPTIVE TECHNOLOGIES GROUP AND EMBODIES A PROPRIETARY DESIGN ORIGINATED BY ADAPTIVE TECHNOLOGIES GROUP ALL DESIGN, MANUFACTURE, REPRODUCTION, USE AND SALE RIGHTS REGARDING THE SAME ARE EXPRESSLY RESERVED. THIS DRAWING MAY NOT BE REPRODUCED OR INFORMATION HEREIN TRANSMITTED IN ANY WAY WITHOUT WRITTEN CONSENT FROM ADAPTIVE TECHNOLOGIES GROUP ALL PATENT RIGHTS HERETO ARE EXPRESSLY RESERVED BY ADAPTIVE TECHNOLOGIES GROUP SIGNAL HILL CALIFORNIA	UNLESS OTHERWISE SPECIFIED:	NAME	DATE	ADAPTIVE TECHNOLOGIES GROUP 1635 E. Burnett Street Signal Hill, CA 90755 Tel: 562-424-1100 Fax: 562-424-3520	
	DIMENSIONS ARE IN INCHES	DRAWN	TBA		08/07/13
	TOLERANCES:	CHECKED			
	FRACTIONAL: $\pm 1/64$	ENG APPR.			
	ANGULAR: MACH $\pm .5^\circ$	MFG APPR.			TITLE: UB-MT-500NPT ASSEMBLY INSTRUCTION
	TWO PLACE DECIMAL $\pm .03$	Q.A.			NEXT ASSY:
	THREE PLACE DECIMAL $\pm .01$	COMMENTS:			USED ON:
	INTERPRET GEOMETRIC TOLERANCING PER:				SIZE B DWG. NO. UB-MT-500NPT REV 00
	MATERIAL:				SCALE: 1:12 WEIGHT: SHEET 1 OF 1
	FINISH:				
DO NOT SCALE DRAWING					