

The FP-AM4212-3X1 planar array kit give designers, contractors and audio consultants the ability to create a three AM4212, or AM6212 or AM5212 speakers in a tight pack configurations. The FasPac™ provides a method of flying a tight pack array while offering the capability of allowing cabinets to be adjusted relative to each other to find the optimum sound directivity. A series of holes are provided to easily adjust the splay angle from 0° to 30° at an increment of 2.5 degree for both AM4212 and AM6212 speakers.

Installing speakers must be performed by experienced professionals. If in doubt about the integrity of the structure you are mounting or suspending to or not sure about the proper hardware or method to use, consult a certified rigging company.

Package contents:

4 pcs	7-6105 Front-Rear Joiner Plate
2 pcs	7-6103 Rear Joiner Plate
14 pcs	Btndhd sckt screw, M10x1.5-45MM long
14 pcs	M10 flat washers

CAUTION: PLEASE READ CAREFULLY BEFORE PROCEEDING

Due to the wide variety of building structures, materials and suspension methods, these instructions assume that the installing contractor/installer will exercise good judgment in selecting the proper mounting area and hardware. As a guide, the installation, when complete, should be capable of supporting at least 5 times the actual load.

Follow building code requirements to safely suspend the speakers to the building structure

Planar Array

Step 1.

Flip speakers so that the bottom is facing up. Unscrew existing speaker screws and discard.

Step 2.

Determine the splay angle of the speaker and the holes to use on the front joiner plate (Figure 2).

Step 3.

Install the rear joiner plate on the rear rigging inserts to secure the side speakers to the center using the slots of the plates. Use the provided M10 screws and washers (Figure 1). Install two front joiner plates on the two front rigging inserts of the speakers using the corresponding holes for the appropriate splay angles, using the M10 eyebolts, screws, and washers (Figure 2). Make sure the markings on the plates are facing up. Do not tighten screws; leave it snug until all plates are in position.

Step 4.

Slowly flip the speaker assembly so that the tops of the speakers are facing up. Unscrew the speaker screw and discard.

Step 5.

Install a rear joiner plate on the rear rigging inserts of the center speaker using the provided M10 screw and washer. Use eyebolts to secure the rear joiner plates to the eyebolts will be use as the pull back points.

For steep angles, Install one eyebolt on the bottom rear of the center speaker. This Will be used for the pull back (Figure 3).

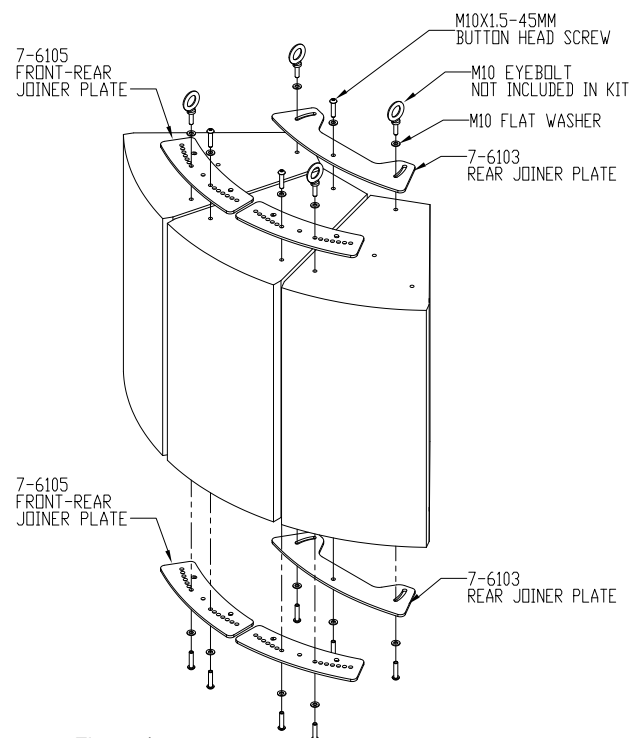

Figure 1

two side speakers (Figure 1). The

Step 7.

When all plates are in position, tighten all screws permanently.

Step 8.

Use the two front eyebolts from the suspension plates as the main speaker suspension points. Use the back eyebolts as a pullback points to adjust the tilt angle of the speaker cluster (Figure 3).

For steep angles, use eyebolt installed on the bottom rear of the center speaker as the pull back point to achieve the desired tilt angle (Figure 3)..

Step 9.

Check all hardware connections before hoisting cluster.

Line Array

Step 1.

Repeat previous step 1 through 5 and replace eyebolts with button head socket screws and place eyebolts on rigging point such as in figure 4 to create a line array (use top two eyebolts as primary suspension points and the lower eyebolt as a pull back point.)

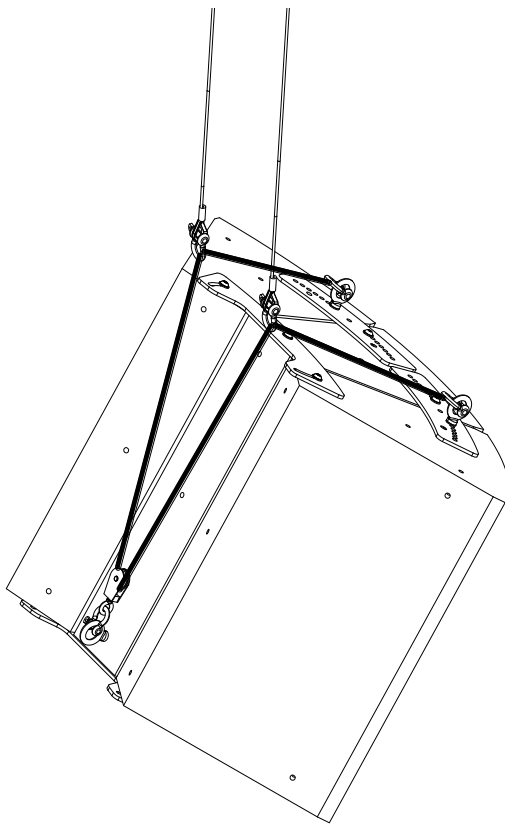

Figure 3

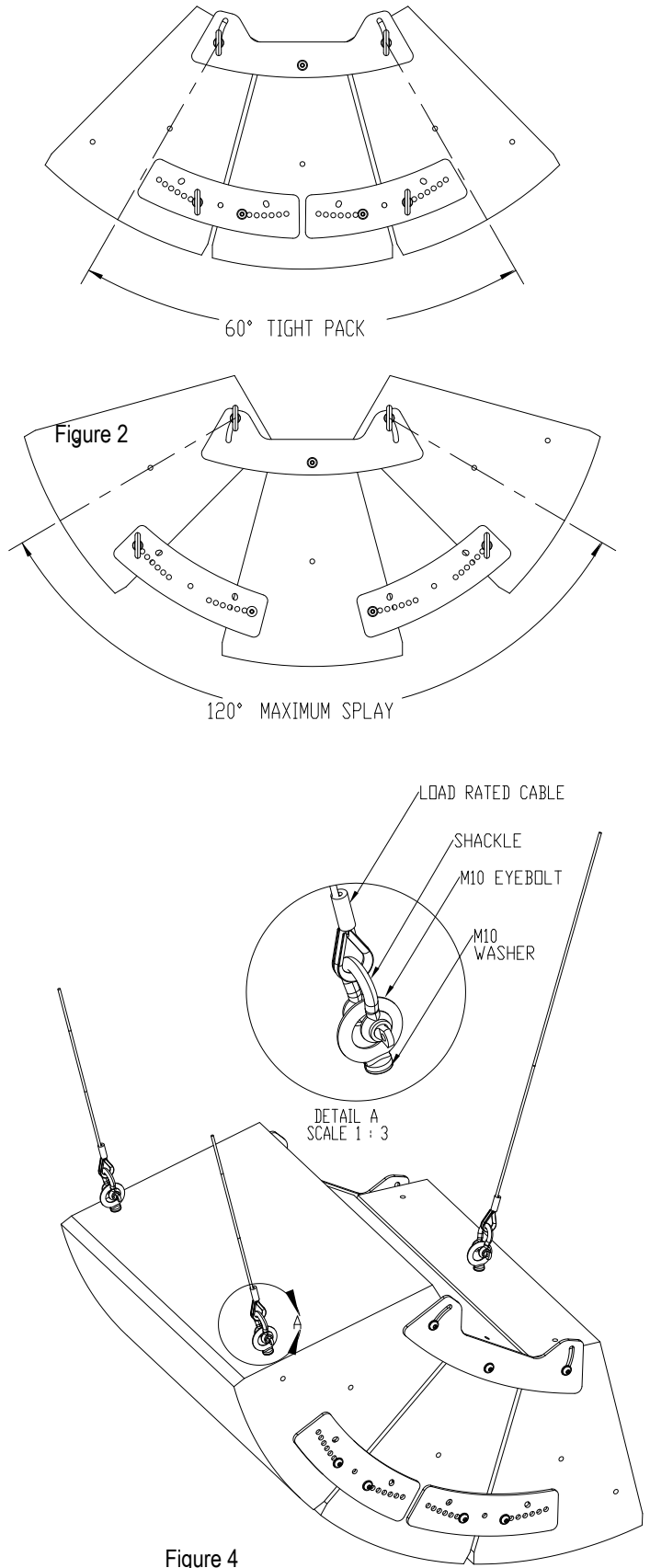

Figure 4